

Indexed

NAVSHIPS **91004**

INSTRUCTION BOOK

For

POWER SUPPLY PP-286/UR

For Use With

CMS-R RECEIVER AND CMS-T TRANSMITTER

91004

Manufactured by

NATIONAL ELECTRICAL MACHINE SHOPS, INC.
SILVER SPRING, MARYLAND

For

NAVY DEPARTMENT

BUREAU OF SHIPS

Contract NObsr-30051

INSTRUCTION BOOK

For

POWER SUPPLY PP-286/UR

For Use With

CMS-R RECEIVER AND CMS-T TRANSMITTER

Manufactured by

**NATIONAL ELECTRICAL MACHINE SHOPS, INC.
SILVER SPRING, MARYLAND**

For

NAVY DEPARTMENT

BUREAU OF SHIPS

Contract NObsr-30051



Figure 1. Power Supply PP-286/UR

POWER SUPPLY PP-286/UR

I

THEORY OF OPERATION

1. The Power Supply PP-286/UR furnishes power to the CMS-R receiver and the CMS-T transmitter either from an AC source or from self contained batteries.
 - a. A.C. Operation: The plate power transformer has primary taps to accommodate A.C. line voltages from 85 to 130 volts, 50 - 60 cycle and from 185 to 260 volts, 50 - 60 cycle. The high voltage secondary works into a type 5U4G rectifier tube and a conventional condenser input filter, giving a D.C. output of 400 volts at 150 milliamperes for transmitter operation, and by means of a tapped bleeder 45 volts D.C. at 5 milliamperes for receiver operation.

Transmitter and receiver filaments are normally supplied by a 3 cell lead-acid storage battery contained in the Power Supply PP-286/UR. During A.C. operation this storage battery is used with the dry disc rectifier battery-charger on, so that the storage battery in effect floats across the filament lines, with little or no drain on the battery.
 - b. Storage Battery Operation: Plate power is provided by a dual vibrapack unit operated from the storage battery. The vibrapack uses the same filter as the A.C. supply. The D.C. output of the vibrapack is 400 volts at 150 milliamperes for transmitter operation, and 45 volts at 5 milliamperes for receiver operation.

Transmitter and receiver filaments are supplied directly by the storage battery. A fully charged storage battery will supply the vibrapack on receiver operation for approximately 3 hours, or on transmitter operation for approximately one hour, without recharging.
 - c. Dry Battery Operation of Receiver: The Power Supply PP-286/UR also contains a 45 volt dry battery, and a 3 volt filament source derived from four 1-1/2 volt flash light cells in series - parallel. This dry battery supply is for receiver operation only.
 - d. Storage Battery Charging: The Power Supply PP-286/UR contains a dry-disc rectifier unit for A.C. charging of the storage battery, and also a separate input for 115 volts or 230 volts D.C. for storage battery charging through built-in series resistances.

- e. Uninterrupted Operation is assured in the event of failure of the A.C. power, by means of a relay which automatically switches the vibrapack on in the event that power from the A.C. line is interrupted.

II

OPERATING INSTRUCTIONS

Prior to the first operation of the Power Supply PP-286/UR, the storage battery should be filled to the level line with electrolyte, and installed in the equipment. The storage battery should then be charged until all three hydrometer balls in each cell are floating. (For instructions on charging, see paragraph 5 of this section.) The dry batteries should also be installed.

1. A.C. Operation:

- a. Before connecting the Power Supply PP-286/UR to the A.C. power line by means of the 20 foot line cord, see that the following switches are in the positions indicated:

<u>SWITCH</u>	<u>POSITION</u>
A.C. Line	OFF
"B" Dry- "B" Powerpack	OFF
Filament	OFF
Charge	OFF

BOTH A.C. LINE VOLTAGE PLUG STRIPS SHOULD BE PULLED OUT.

- b. Connect the A.C. Line receptacle on the Power Supply PP-286/UR to the source of A.C. power by means of the line cord. Note the A.C. Line voltage on the meter.
- c. Insert the A.C. line voltage plug strips into the jack holes corresponding most closely to the voltage shown on the meter.
- d. Plug the receiver and transmitter power cords into the receptacles marked RECVR. and TRANS.
- e. Turn the following switches to the positions indicated:

<u>SWITCH</u>	<u>POSITION</u>
A.C. Line	ON
"B" Dry- "B" Powerpack	"B" Powerpack
Filament	ON
Charge	ON*
Charging Rate	To tap at which meter indicates approx. 2 amp charging rate.

***CAUTION:**

Whenever the charger is in use, the ventilating doors on the top and left side of the Power Supply must be opened.

Power will now be available either to the transmitter or receiver depending on the position of the SEND - REC. switch.

If during A.C. operation the A.C. power lines fail, the vibrapack will automatically go into operation, provided the storage battery is not too greatly discharged to operate the vibrapack.

2. A.C. Operation with Storage Battery Removed:

If for any reason the storage battery must be removed from the Power Supply PP-286/UR, the unit may be operated on A.C. without a storage battery. In this case filament voltages for transmitter and receiver are obtained directly from the dry disc rectifier battery charger. Operation is the same as for normal A.C. operation, with CHARGE switch ON, except that the charging rate must be carefully adjusted as follows:

CAUTION: Too high a charging rate may burn out tube filaments when the storage battery is removed from the circuit of the Power Supply PP-286/UR. Therefore the CHARGING RATE switch should be set at position 1 before turning the FILAMENT switch on. After the filament switch has been turned on, notice the charging rate as indicated on the meter.

If the receiver only is plugged into the Power Supply PP-286/UR, the CHARGING RATE switch should be advanced only until the meter reads approximately 1.2 amperes.

If the receiver and transmitter both are in use, it is necessary to note whether 6V6 tubes or 6L6 tubes are being used in the transmitter. With 6V6 tubes in the transmitter, the CHARGING RATE should be adjusted to 2.1 amperes. With 6L6 tubes in the transmitter, the CHARGING RATE should be adjusted to 3.0 amperes.

3. Vibrapack Operation:

- a. Plug the receiver and transmitter cords into the receptacles marked RECVR. and TRANS.
- b. Turn the following switches to the positions indicated:

<u>SWITCH</u>	<u>POSITION</u>
Filament	ON
"B" Dry- "B" Powerpack	"B" Powerpack
"A" Dry- "A" Storage	"A" Storage

Power will now be available either to the transmitter or receiver depending on the position of the SEND - REC. switch.

4. Dry Battery Operation of Receiver:

The receiver only may be operated with the dry batteries as follows: Plug the receiver power cord into the receptacle marked RECVR, and turn the following switches to the position indicated:

<u>SWITCH</u>	<u>POSITION</u>
Filament	ON
"B" Dry- "B" Powerpack	"B" Dry
"A" Dry- "A" Storage	"A" Dry

Power will now be available to the receiver when the SEND - REC. switch is in the REC. position.

5. Storage Battery Charging:

CAUTION: Whenever the battery is being charged, either with A.C. or D.C., the ventilating doors on the top and left side of the Power Supply must be opened.

- a. When A.C. is available, the storage battery may be charged by means of the dry disc rectifier built into the PP-286/UR. The same plug strips that are used to match the power transformer to the line voltage also match the battery charging transformer to the line. Before turning any switches on, see that the ventilating doors are open, and insert the plug strips in the position corresponding to the line voltage indicated by the meter. Then turn the CHARGE switch to the ON position, and adjust the CHARGING RATE switch to a tap that gives a charging rate of not more than 2.6 amperes, as indicated on the meter. (See section III, Maintenance, paragraph 1b, for determining the condition of the storage battery.)
- b. When 115 v. or 230 v. D.C. only is available, the storage battery may be charged as follows: See that the ventilating doors are open. Connect jumpers from + to + and - to - on the charging circuit Output and Storage Battery terminals on the front panel. Turn the D.C. CHARGE switch to 230 v. or 115 v. depending on the D.C. line voltage available. Finally, connect the D.C. LINE receptacle on the panel to the D.C. line by means of the line cord which is polarized and can only be attached in the correct polarity. The D. C. line dropping resistors are located inside the ventilating doors on the left side of the unit. These resistors are of such a value that they give a charging rate of approximately 2.6 amperes. If the D.C. line voltage is 115 volts, and a lower charging rate is desired, the D. C. CHARGE switch may be turned to the 230 v. position, giving a charging rate of approximately 1.3 amperes.

6. Charging an External Battery:

- a. A.C. charging of an external battery may be accomplished by connecting it to the charging circuit STOR. BAT. terminals by means of the battery cable provided in the cover of the Power Supply PP-286/UR.
When using A.C. for charging an external battery it is advisable to disconnect the storage battery inside the Power Supply PP-286/UR.
- b. D.C. charging of an external battery may be done by connecting to the charging circuit OUTPUT terminals, and plugging 115 volts or 230 volts D.C. into the D.C. LINE receptacle as for charging the battery inside the Power Supply.

III

MAINTENANCE

1. Storage Battery:

- a. The level of the electrolyte in the storage battery should be checked approximately every three days, and distilled water should be added when necessary, to maintain the level of the electrolyte at the LEVEL LINE marked on the side of the battery.
- b. The storage battery should be charged whenever the green and white balls are down in one or more cells. Gas bubbles sometimes cling to the balls, causing them to float even though the cell is so discharged that they normally would sink. Therefore it is advisable to tip the battery a little and tap the wall of the battery gently, to dislodge any gas bubbles from the balls, so that a reliable indication of battery condition may be had. The position of the colored hydrometer balls indicates the specific gravity of each cell, as follows:

GREEN BALL SINKS	at sp. gr.	1.268	Battery - 10% Discharged
WHITE BALL SINKS	at sp. gr.	1.220	Battery - Half Discharged
RED BALL SINKS	at sp. gr.	1.150	Battery - Fully Discharged

A cell is fully charged when the specific gravity at 70° F. is 1.280. It is advisable to recharge the battery whenever the specific gravity falls to 1.200.

2. Dry Batteries:

- a. The service life of the 45 volt B battery in the Power Supply PP-286/UR is approximately 280 hours, based on the receiver current drain of 5 milliamperes applied intermittently. The service life of the four 1.5 volt flashlight cells, which are connected in series - parallel to give 3 volts for receiver tube filaments, is approximately 14 hours, based on a current drain of 180 milliamperes, applied intermittently.

- b. The B battery may be tested under load by applying a voltmeter with a minimum sensitivity of 1000 ohms/volt to the battery terminals by means of test prods, while the receiver is in operation.
The B battery should be discarded when its voltage is below 34 volts when tested under normal load.

The A battery may be tested under load by applying the voltmeter test prods to the terminal lugs at the back of the battery case. The A batteries should be discarded when their voltage is below 2.4 volts, under normal load. (Based on minimum filament voltage for satisfactory operation of type 3S4 tubes as used in CMS-R receiver.)

If a battery tester is available, the batteries may be removed from the case and tested to determine whether or not they are in need of replacement.

- c. NOTE: DEAD BATTERIES SHOULD NOT BE LEFT IN THE CASE, BECAUSE THEY MAY CAUSE DAMAGE AS A RESULT OF LEAKING OR SWELLING.
3. The following trouble shooting chart will be of help in locating ordinary causes of failure of operation of the Power Supply PP-286/UR.

Trouble Shooting Chart

Symptom	Check	Remedy
A.C. output fails (A.C. AVAILABLE pilot light on but voltmeter does not indicate.)	A.C. line fuses (2 amp.)	See that A.C. LINE plug strips were in proper position. Replace blown fuse.
A.C. output fails (A.C. AVAILABLE pilot light on and voltmeter indicates normal line voltage.)	5U4G rectifier tube.	Replace 5U4G tube.
Relay chatters but does not hold when A.C. power is on and "B" switch is thrown to "B" Powerpack.	Position of A.C. LINE plug strips.	Insert A.C. LINE plug strips in position corresponding to line voltage.
Vibrapack will not operate. (When vibrapack is operating a slight vibration can be felt in the frame of the power supply.)	a. Condition of storage battery. b. Vibrapack fuses (12 amp.) c. Battery fuses (20 amp.) d. 6X5 rectifier tubes in vibrapack. e. Vibrator units.	a. Charge battery if low. b. Replace blown fuse. c. Replace blown fuse. d. Substitute new tubes. e. Substitute new vibrator units.

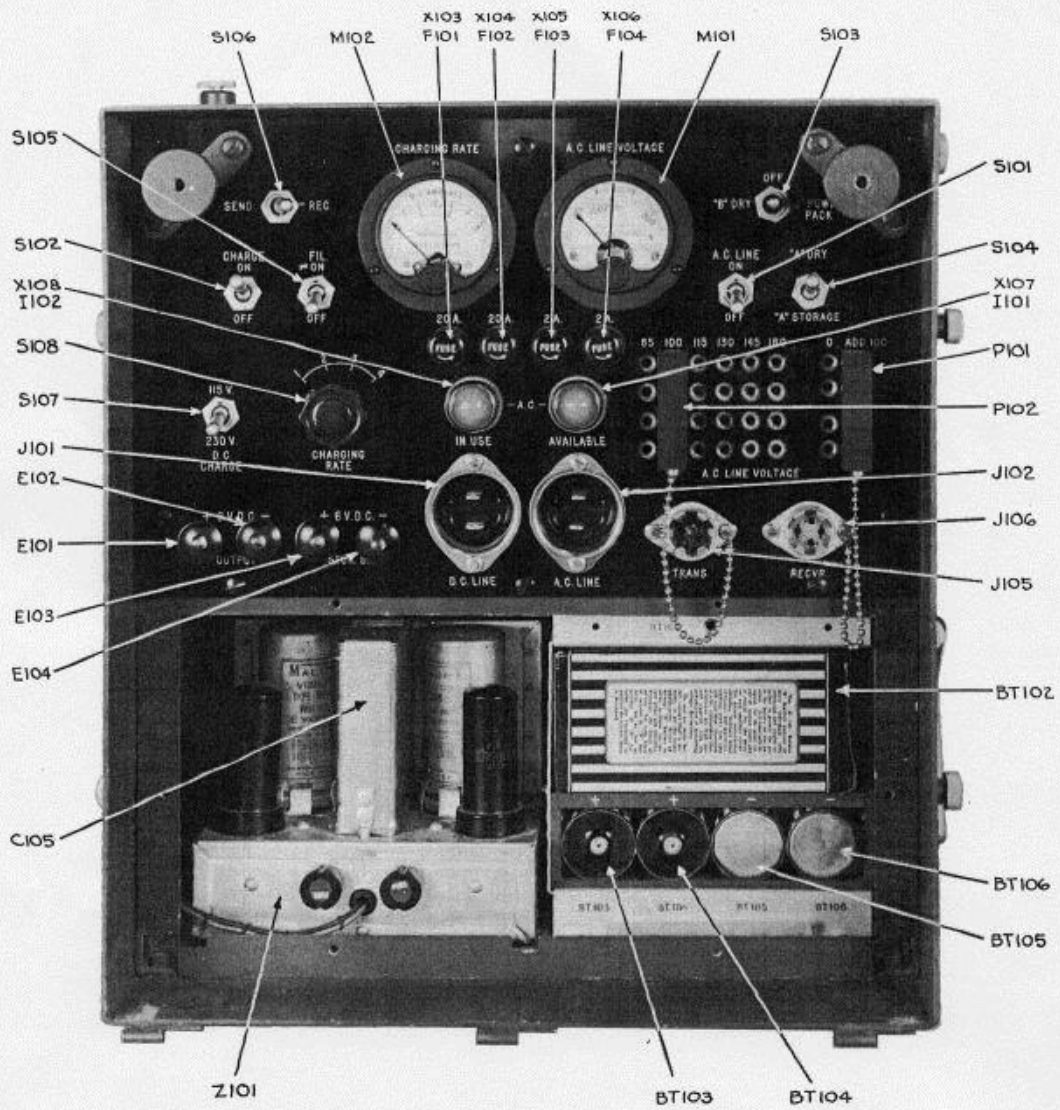

Figure 2. Front View, Lower Panel Removed

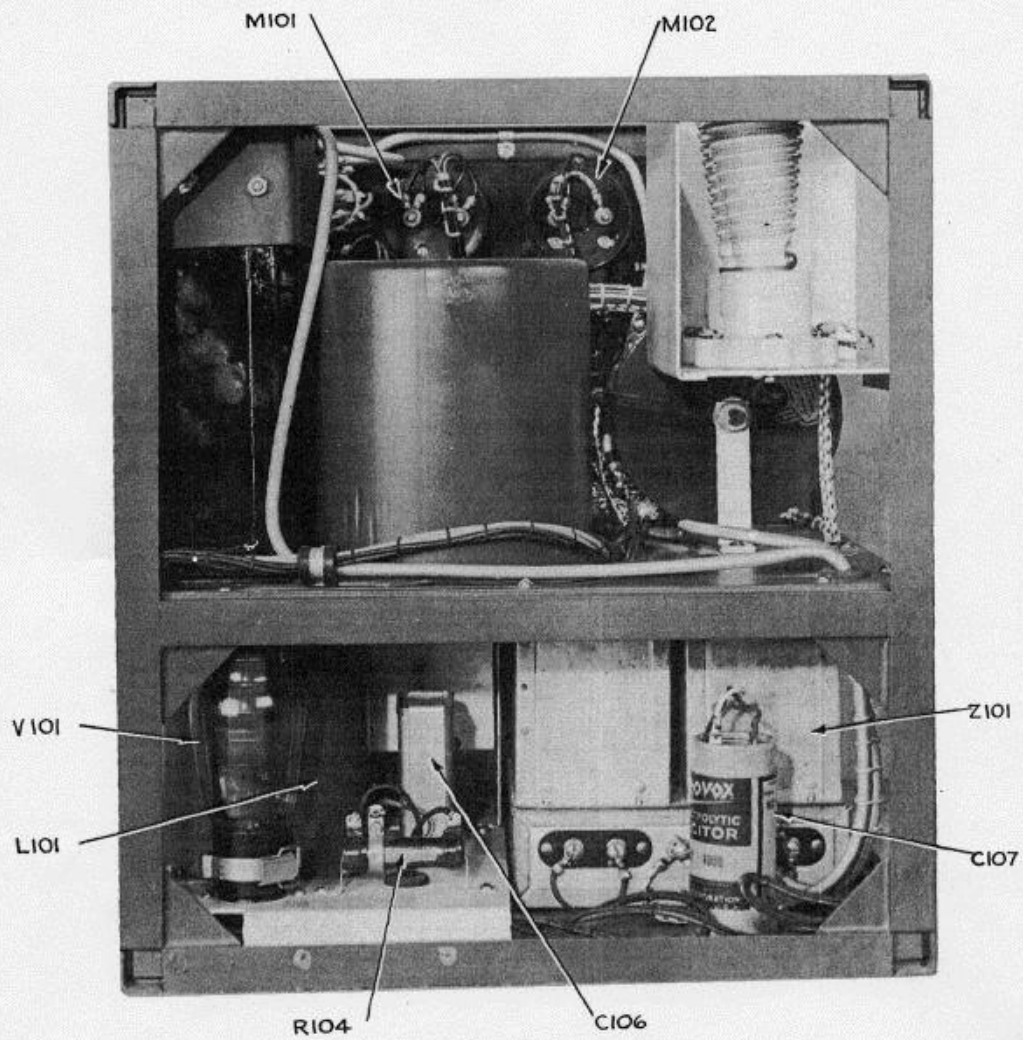

Figure 3. Rear View of Chassis

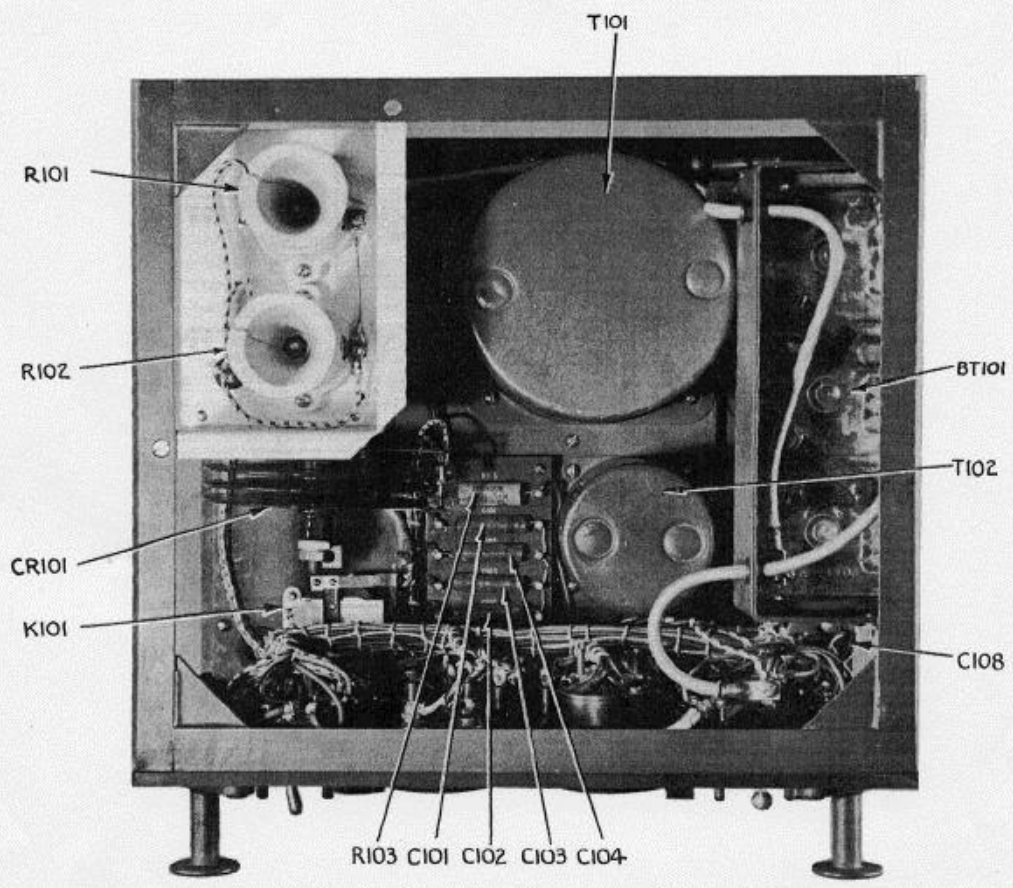
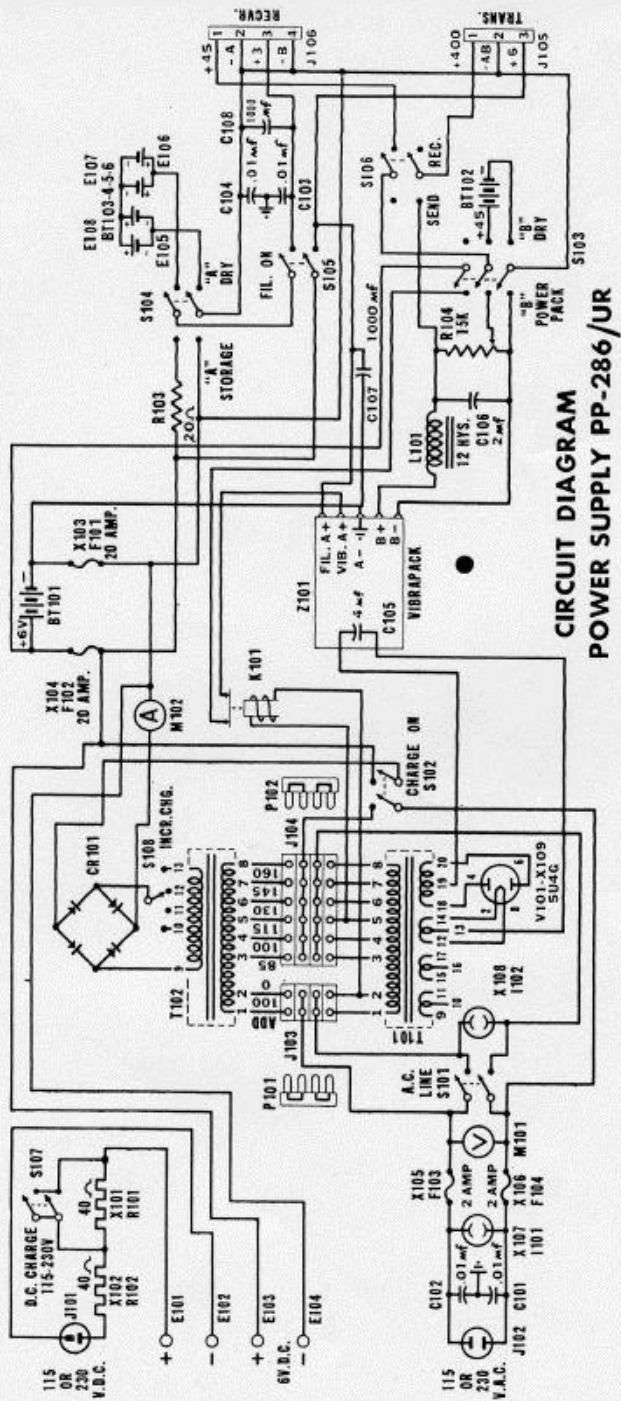

Figure 4. Top View of Chassis



CIRCUIT DIAGRAM
POWER SUPPLY PP-286/UR

Figure 5. Circuit Diagram - Power Supply PP-286/UR

Trouble Shooting Chart (Cont'd)

Symptom	Check	Remedy
	f. K101 Relay Contacts.	f. Clean contacts with fine sandpaper.
"A" STORAGE filament voltages to receiver or transmitter fail.	a. Battery fuses (20 amp.) b. See that storage battery leads are connected.	a. Replace blown fuse. b. Connect battery leads.
No charging rate indicated by meter when CHARGE switch is on.	a. Battery fuses (20 amp.) b. See that storage battery leads are connected.	a. Replace blown fuse. b. Connect battery leads.
Low charging rate. (Below 2 amperes when all three balls are down in all storage battery cells, and CHARGING RATE switch is on tap 4.)	Dry disc rectifier probably worn out.	Replace disc rectifier

4. Circuit Checking: Circuit faults may be located by means of the following continuity check list, together with the circuit diagram, Figure 5. The following checks should be made with an ohmmeter.

CAUTION: Disconnect storage battery and remove dry batteries before making any circuit checks.
See that A.C. line cord is withdrawn from A.C. LINE receptacle.

From	To	Remarks	Resistance in Ohms
J102 upper pin	J104 all jacks in second horizontal row down from top	S102 on	0
J102 upper pin	J104 all jacks in third horizontal row down from top	S101 on	0
J102 lower pin	J103 both jacks in second horizontal row down from top		0
J102 lower pin	J103 both jacks in second horizontal row down from top	S101 on	0

Continuity Check List (Cont'd)

X109 pin 4 and 6	J105 pin 2 (B-)	S103 -"B" Powerpack	45
X109 pin 2 and 8	J105 pin 2 (B-)	S103 -"B" Powerpack	Approx. 15,300
J106 pin 2 and 4	J105 pin 2 (B-)		0
J106 pin 1	J105 pin 2 (B-)	S106-REC. S103 "B" Powerpack	1250
J106 pin 3	J105 pin 2 (B-)	S104 "A" Storage S105 on	21
J105 pin 1	J105 pin 2 (B-)	S103 "B" Powerpack S106 Send	15,000
J105 pin 3	J105 pin 2 (B-)		1
E105	J105 pin 2 (B-)	S104 "A" Dry	0
E104	J105 pin 2 (B-)		0
BT102(-)lead	J105 pin 2 (B-)	S103 "B" Dry	0
BT101(-)lead	J105 pin 2 (B-)		0
E103	CR101 red term.	S102 on	0
E103	Z101 Vib. A+	S103 "B" Powerpack	0
E102	J101 large pin		0
E101	J101 small pin	S107-230v.	80
E101	J101 small pin	S107-115v.	40
E106	J106 pin 3	S105 on S104 "A" Dry	0
BT101(+)lead	J106 pin 3	S105 on S104 "A" Storage	20
BT102(+)lead	J106 pin 1	S103 "B" Dry S106 Rec.	0

Continuity Check List (Cont'd)

CR101 black term.	M102(+)term.		0
E104	M102(-)term.		0
J102 top pin	C101 inside foil		0
J102 bottom pin	C102 inside foil		0
J106 pin 3	C103 inside foil		0
J106 pin 2	C104 inside foil		0
Chassis	C101 outside foil		0
Chassis	C102 outside foil		0
Chassis	C103 outside foil		0
Chassis	C104 outside foil		0
J102 top pin	X107 bottom term.		0
J102 top pin	M101 left rear term.		0
J102 top pin	X108 top term.	S101 on	0
J102 bottom pin	X107 top term.		0
J102 bottom pin	M101 right rear term.		0
J102 bottom pin	X108 bottom term.	S101 on	0
C107(+)term.	Z101 (A + Fil.)		0
C107(-)term.	Z101 (A -)		0
C108(+)term.	J106 pin 3		0
C108(-)term.	J106 pin 2		0
J103 ADD 100 top row	J103 - 0 top row		37
J103 ADD 100 top row	J104 - 85		51
J103 ADD 100 top row	J104 - 100		53
J103 ADD 100 top row	J104 - 115		56
J103 ADD 100 top row	J104 - 130		60
J103 ADD 100 top row	J104 - 145		65
J103 ADD 100 top row	J104 - 160		70

Continuity Check List (Cont'd)

J103 ADD 100 bottom row	J103 - 0		2.9
J103 ADD 100 bottom row	J103 - 85		4.0
J103 ADD 100 bottom row	J105 - 100		4.4
J103 ADD 100 bottom row	J105 - 115		4.8
J103 ADD 100 bottom row	J105 - 130		5.2
J103 ADD 100 bottom row	J105 - 145		5.7
J103 ADD 100 bottom row	J105 - 160		6.1
CR101 yellow term.	CR101 other yellow	S108 Position 4	0.1 Approx.
K101 one side of coil	K101 other side of coil		2.0
C106 red lead	J105 pin 1	S106 SEND	0
C106 black lead	J105 pin 2 (B-)	S103 "B" Powerpack	0

ERRATA:

Page 10, line 2, J104 - 85 for J103 - 85
 Page 10, lines 3-7, J104 for J105

IV

PARTS LIST

Power Supply PP-286/UR

Quantity	Symbol	Item	Navy Type Number	Manufacturer's Designation
1	--	Power Supply in carrying case	PP-286/UR	NEMS - AD3441
1	WI01	Power Cord	CN-62384	NEMS - AB3621
1	WI02	Battery Cable	CN-62383	NEMS - AB3634
1	BT101	Storage battery, 6 volt portable	CWB-19061	Willard ER-25-6
1	BT102	B Battery, 45 volt	CBR-19005	Burgess No. 5308
4	BT103-4-5-6	Flashlight cell, 1.5 volt	CBR-19031	Burgess No. 2
1*	--	Quart Bottle of Electrolyte for BT101, Sp. Gr. 1.280		Willard
2	--	Instruction Books		NEMS

* Packed separately

V
SPARE PARTS LIST
Power Supply PP-286/UR

Quan.	Symbol	Item	Navy Type Number	Manufacturer's Designation
1	CR101	Rectifier stack, dry disc	CBGG-20601	Accurate Eng. Co. Code No. DE1701K
1	V101	Type 5U4G tube	JAN-5U4G	R.C.A. 5U4G
1	M102	Ammeter 0-3 amp. D.C.	MR25W003DCAA	G.E. Model 51ATE49 AAL Type DW
1	M101	Voltmeter 0-300 volts A.C.	MR25W300ACVV	G.E. Model 42VAV5M 101 Type AW
1	S108	Switch, rotary, 4 PST	COM-241267	Ohmite Model 111-4
1	S104,6	Switch, toggle, DPDT	ST52N	Cutler Hammer 8825K4
1	S101,2 5, 7	Switch, toggle, DPST	ST52K	Cutler Hammer 8823K4
1	S103	Switch, toggle, 3PDT, center off	CAE-241266	Cutler Hammer 7612K2
1	P101	Plug strip, 0-ADD 100	CN-491761	NEMS - AA3461
1	P102	Plug strip, 85-160 v.	CN-491760	NEMS - AA3460
1	Z101	Vibrapack	CMA-20600	Mallory VP-557
1	K101	Relay, SPST, normally closed	CPB-291588	Price Bros. 1605
1	TL01	Transformer, plate power	CUT-304345	U.T.C. SH-4504
1	TL02	Transformer, battery charging	CUT-304344	U.T.C. SH-4305

Quan.	Symbol	Item	Navy Type No.	Manufacturer's Designation
1	L101	Choke, filter	CUF-304346	U.T.C. SH-4303
1	X109	Socket, tube, octal	CPH-49374	Amphenol MLP-8
1	C106	Capacitor, oil filled, 2 mfd. 600 v.	CP70B1DF205K	Sprague CP70B1DF205K
2	R103	Resistor, 20 ohm 5 watt, wire wound	CSF-636094-5	Sprague "Koolohm" 5K
4	C101, 2, 3, 4	Capacitor, paper tubular, .01 mfd. 600 v.		Solar XTLM06-.01
2	C107, 8	Capacitor, dry electrolytic, 1000 mfd. 12 v.	CAW-484690	Aerovox Type HCLV
2	I101, 2	Lamps, neon, candelabra base, 1/4 w.		G.E. T4 $\frac{1}{2}$
2	X107, 8	Socket, pilot lamp, opal jewel		Dial Light Co. 721214-145
1	X101, 2	Lamp socket, porcelain, surface mtg.		G.E. 28795
1	W101	Power Cord	CN-62384	NEMS AB3621
1	J102	Receptacle, motor base type	CPH-49643	Amphenol 61-M10
1	J101	Receptacle, motor base type, polarized	CPH-491759	Amphenol 61-MP10
1	P103	Plug, female, for line cord	CPH-49800	Amphenol 61-F11
1	P104	Plug, male, for line cord, polarized	CPH-491758	Amphenol 61-MP11
2	F103, 4	Fuse, 2 amp, type 3AG	CFA-28030-2	Bussman 3AG-2

Quan.	Symbol	List	Navy Type No.	Manufacturer's Designation
2	F101,2	Fuse, 20 amp, type SFE	CFA-28030-20	Bussman SFE-20
1	J105	Connector, 3 contact, female	CPH-491418	Amphenol PCG3F
1	J106	Connector, 4 contact, female	CPH-491757	Amphenol PCG4F
1	BT101	Storage battery, 6 volt, portable	CWB-19061	Willard ER-25-6
1*		Quart bottle of Electrolyte for BT101, Sp. Gr. 1.280		Willard
2	X103,4 5, 6	Fuse holder, extractor post type		Bussman HKM
2	R101,2	Heater element, screw base, 40 ohm	CN-636096	NEMS AA-3680
1	W102	Battery Cable	CN-62383	NEMS AB-3634
2	R104	Resistor, adjustable, 15,000 ohm, 25 watt	COM-636095-10	Ohmite No. 0387

* Packed separately

LIST OF MANUFACTURERS

ABBREVIATION	NAME	ADDRESS
Accurate Eng. Co.	Accurate Engineering Co., Inc.	5246 N. Clark St. Chicago, Ill.
Aerovox	Aerovox Corporation	New Bedford, Massachusetts
Amphenol	American Phenolic Corp.	1832 S. 54th Ave. Cicero, Ill.
Burgess	Burgess Battery Co.	Freeport, Ill.
Bussman	Bussman Manufacturing Co.	2534 W. University St., St. Louis, Mo.
Cutler-Hammer	Cutler-Hammer, Inc.	1407 W. St. Paul Ave., Milwaukee, Wisconsin
Dial Light Co.	Dial Light Company of America, Inc.	94 West Street New York, N. Y.
G.E.	General Electric	1287 Boston Ave. Bridgeport, Conn.
Mallory	P. R. Mallory and Co., Inc.	3027 E. Washington Ave., Indianapolis, Indiana
NEMS	National Electrical Machine Shops, Inc.	919 Jesup-Blair Drive Silver Spring, Md.
Ohmite	Ohmite Manufacturing Co.	4905 Flournoy Street Chicago 44, Ill.
Price Bros.	Price Brothers Company	Frederick, Maryland
R.C.A.	Radio Corporation of America	Harrison, New Jersey
Solar	Solar Manufacturing Corp.	Bayonne, New Jersey
Sprague	Sprague Products Company	North Adams, Mass.
U.T.C.	United Transformer Corp.	146 Varick Street New York, N. Y.
Willard	Willard Storage Battery Co.	E. 131st. Street and St. Clair Ave., Cleve- land, Ohio